

Fiber Optic Splice Closures

Table of Contents		Page
1.	General Product Information	2
2.	Warnings	3
3.	Required Tools and Materials	3
4.	Standard Components	3
5.	General Installation Notes	3
6.	Supplementary Kits	4
7.	Cable Preparation	5
7.1	Loose Buffer Tube Cable End Prep	5
7.2	Loose Buffer Tube Cable Mid-Span Prep	6
7.3	Central Core Tube Stranded Fiber End Prep	6
7.4	Central Core Tube Ribbon Cable End Prep	7
7.5	Central Core Tube Cable Mid-Span Prep	7
7.6	Loose Buffer Tube Ribbon Cable End Prep	7
7.6	Loose Buffer Tube Ribbon Cable Mid-Span	7
8.	Remove Dome/Base Seal	8
9.	Install Cables	8
9.1	Bond and Ground Metal Components	8
9.2	Attach Central Members	9
9.3	Seal Cables in Oval Port	9
10.	Fiber Organizing	10
10.1	Loose Buffer Tube and Central Core Tube Cable - Stranded Fiber with Funnels	10
10.2	Central Core Tube Stranded Fiber Cable - Alternative Method	10
10.3	Central Core Tube and Loose Buffer Tube Ribbon Cable	10
10.4	Add/Remove Splice Trays	10
10.5	Add Intertray Jumpers	11
10.6	Splice Fibers and Store on Trays	11
11.	Closing and Mounting Closure	12
11.1	Install Dome	12
11.2	Test Seal	12
11.3	Mount Closure	12
12.	Adding Cables	13
13.	Removing Cable Seals	13

1. General Product Information

This installation practice provides instructions for installing Tyco Electronics' FOSC 400 B2 and FOSC 400 B4 fiber optic splice closures, henceforth referred to as the "B" closures or the "B2" and "B4".

B closures are a combination cable closure and splice organizer. They combine mechanical seals and heat-shrinkable sleeves with hot-melt adhesives to environmentally seal fiber cable splice points.

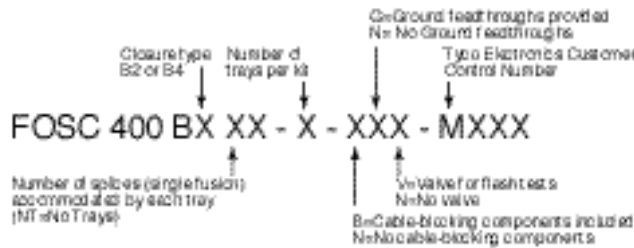

B closures are available in several configurations, as described by the kit naming convention described below.

Cables

The chart below indicates each port's capacity:

B2 Port	Capacity	Cable Diameter Range (inches)
Oval	2 cables	0.4 to 1.0
Round	1 or 2 cables each	0.2 to 1.25

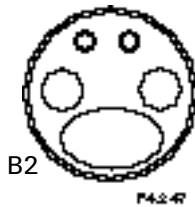

B4 Port	Capacity	Cable Diameter Range (inches)
Oval	2 cables	0.4 to 1.0
Round	1 or 2 cable each	0.2 to .75



B closures accommodate cable with any combination of the following characteristics:

Cable Types:

- Loose buffer tube (stranded-fiber and ribbon)
- Central core tube (stranded-fiber and ribbon)
- Slotted core cable

Strength Member/Shield Types:

- Dual strength member
- Central member
- Unshielded
- Shielded
- Double-shielded

Fiber Types:

- Single-fiber (250 micron or 900 micron tight-jacket)
- and Ribbon

Splices

Standard B closure kits are supplied with one splice tray which can accommodate two splice modules. There are different types of splice modules. Refer to the Naming Convention section (page 2) to determine which type of splice module is included in the tray for this kit. The chart below identifies the number and type of splices accommodated by each type of splice module:

Splice Modules	Splice Accommodation	Splices per Tray	Tray Kit
SM6	Mass fusion	12	B Trays 12 - 2
	Single fusion (60mm)	12	
	Single mechanical	12	
SM8	Single fusion (40mm)	16	B Trays 16 - 2
	Single fusion (60mm)	16	
	Single mechanical	8	
SM12	Single fusion (40mm)	24	B Trays 24 - 2
	Single fusion (60mm)	24	
	NT QPAK	24	
SMMM	Mass Mechanical	2	N/A

* For SM12, use Raychem SMOUV or fusion splice protectors having a max. recovered diameter of 0.105".

Locations

B closures accommodate unpressurized fiber cable in these locations:

- direct buried
- aerial
- underground (manhole)

2. Warnings

As with any electrical equipment, various safety precautions should be noted when operating a hot-air gun. Please take note of these warnings:

1. Keep the area clear of all combustible materials and gases, such as gasoline, solvents, and dirty rags. Consult your company-approved practice for procedures to clear and ventilate the work area to avoid the potential for fire and/or explosion.
2. The cleaning tissues provided in the kit are extremely flammable, and should not be exposed to excessive heat or open flame.
3. Do not immerse the hot-air gun in water, as electrical shock could occur.
4. Flash test the closure to no more than 5 psi.

3. Required Tools and Materials

You will need these tools and materials to install B closures:

- AC power source capable of providing at least 1750 watts of power
- FOSC closure work stand (FOSC-ACC-Work Stand (optional))

- Snips and sheath knife
- Buffer tube cutter
- Hot-air gun with tip (FOSC ACC CV 1981)
- Assorted hand tools, such as a hacksaw, screwdrivers, pliers, crescent wrenches, can wrench
- White marking pencil
- Locally approved cleaning solution
- Tape measure
- Clean, dry cloths

4. Standard Components

The following items are included in B Fiber Optic Splice Closure kits:

Basic Components:

- base
- splice organizer tray(s) with dust cover
- velcro strap
- dome
- mechanical dome-to-base seal and o-ring

Cable Termination Components:

- heat-shrinkable cable seal for the oval port
- aluminum tape
- branch-off clip
- abrasive strip
- cleaning tissues
- bond wires and clamps
- 2 distribution funnels and caps
- 2 heat-shrink tubes for use with funnels
- small transportation tubes
- large transportation tubes
- buffer tube identification labels
- tie wraps
- installation instructions

Cable Blocking Components**:

- yellow adhesive rings
- adhesive foam strips
- clear heat-shrinkable tubes
- abrasive strip
- cleaning tissues
- tie wraps
- installation instructions

**** Cable blocking components are not included in all kits. Refer to the Naming Convention section of this practice (Page 2) for further details.**

5. General Installation Notes

To ensure the proper performance of the heat-shrinkable sleeves, take note of these precautions:

1. Do not install the heat-shrinkable sleeves at temperatures below -1°C (30°F).
2. If the cable is wet, dry the cable before installing the heat-shrinkable sleeve. Steam generated during heating will cause gaps in the adhesive, resulting in a faulty seal.

6. Supplementary Kits

The following chart identifies supplementary kits available for use with the B closures, and briefly describes their uses.

Kit Name	Usage
FOSC ACC Cable Seal -1 NT	Cable sealing kit (T=tubular seal) for installing one cable in any round port.
FOSC ACC Cable Seal -1 BT	Same as above with cable blocking components.
FOSC ACC Cable Seal-1 NW	Wraparound cable seal (sleeve only) for use on any round port.
FOSC ACC Cable Seal 2 NW	Wraparound cable seal (sleeve only) for use on any oval port.
FOSC ACC Branch Off Clip	25 branch-off clips plus aluminum tape for installing two cables in one port. (Use with FOSC ACC Cable Seal 1-XX Kits.)
FOSC ACC A/B O-Ring Seal	Replacement O-Ring
FOSC ACC B Trays 12-2	B Splice trays with 2 SM6 splice modules (12 splices/tray)
FOSC ACC B Trays 16-2	B Splice trays with 2 SM8 splice modules (16 splices/tray)
FOSC ACC B Trays 24-2	B Splice trays with 2 SM12 splice modules (24 splices/tray)
FOSC ACC B Basket - LBT	Basket for storing express Loose Buffer Tubes
FOSC ACC B Basket - CCT	Basket for storing express stranded fibers from Central Core Tube cable
FOSC ACC B Basket - Ribbon	Basket for storing express or slack ribbon fiber (occupies 2 tray spaces)
FOSC ACC CB Sleeve W	Wraparound sleeve for cable blocking looped cable in any oval port.
FOSC ACC TTube Ribn-16"	Ribbon (7/32") Transportation tubes, 16" (six 12-fiber ribbons per tube).
FOSC ACC TTube Lrge 16"	Large (3/16") Transportation tubes, 16" (for 12-fiber loose buffer tubes)
FOSC ACC TTube Smll 16"	Small (5/32") Transportation tubes, 16" (for 6-fiber loose buffer tubes and funnels)
FOSC ACC Funnel-Ribbon	Funnel and ribbon transportation tubing for routing ribbons from cable to trays.
FOSC ACC Fiber Ext Grnd	External ground or "FEG" kit to isolate one cable ground through port.
FOSC ACC Aerial Clamps	Clamps for mounting A, B, or D closures to an aerial strand.
FOSC ACC A/B Pole Mount	Bracket to mount A or B closures to pole or wall.
FOSC ACC Desiccant	Bags of desiccant (75g) Use one bag in A and B closures, two bags in D closures
FOSC ACC Dome Holder	Holds dome and base together while dome/base clamp is installed.
FOSC ACC Port Rods - 0.5	Provides a .5" plug to be used with cable seals in closing open ports.

7. Cable Preparation

Cable core blocking is optional with B closure kits. If cables are to be blocked prior to installation in a splice closure, ignore the instructions in this section and refer to the instructions on cable preparation included with the Cable Blocking Components.

The instructions that follow address the preparation of loose buffer tube and central core tube (stranded fiber and ribbon) cable. Preparation of cable ends and mid-span cables is explained. Refer to the appropriate section:

Fiber Type	Cable Type	Cable Ends (See Sect. #)	Midspan Opening (See Sect. #)
Stranded (Loose) Fiber	Loose Buffer Tube	7.1	7.2
	Central Core Tube	7.3	7.5
Ribbon Fiber	Loose Buffer Tube	7.6	7.7
	Central Core Tube	7.4	7.5

7.1 Loose Buffer Tube Cable End Preparation

To prepare the ends of loose buffer tube cable, follow these steps:

- Clean the cable and remove 48" of the outer cable sheath and shield if present. Remove the aramid and fiber yarns to the ring cut.
 - Cut central member 9" from the ring cut. (Figure 1)
 - Strip away any insulation present on the central member all the way back to the ring cut.
 - If a shield is present in the cable, tab the cable 1" from the ring cut. Crimp the alligator bond clamp to the tab in the sheath.
 - If you are using a B-Bond clamp on double-armored cable, remove a 1" square section of the outer cable sheath around the tab. (Figure 2) Slide the lower plate of the bond clamp under the inner shield so that the stud bolt sticks up through the tab. Place the upper plate of the B-Bond clamp over the bolt. Place a double-eyelet bond wire (available in the FOSC ACC closure bond wire kit) over the bolt. Install the nut on the bolt and tighten it. Cut off the excess stud bolt and file it flush with the nut. (Figure 3)
 - Attach cable end to the FOSC closure work stand using a tie wrap as shown. (Figure 4)
 - Carefully ring cut and remove all but three inches of each buffer tube. Clean the remaining buffer tubes, exposed fibers, strength members, and 6" of the cable sheath with a cloth and company-approved cleaning solution. (Figure 5)
 - Install one transportation tube on each buffer tube and slide it down to the sheath ring cut.
- Note: Two sizes of transportation tube are provided for six-fiber and twelve-fiber buffer tubes.**
- Wrap cable with vinyl tape from 1" below the bond clamp to 2" above the ring cut to hold transportation tubes in place.
 - Place an identification marker on each transportation tube.

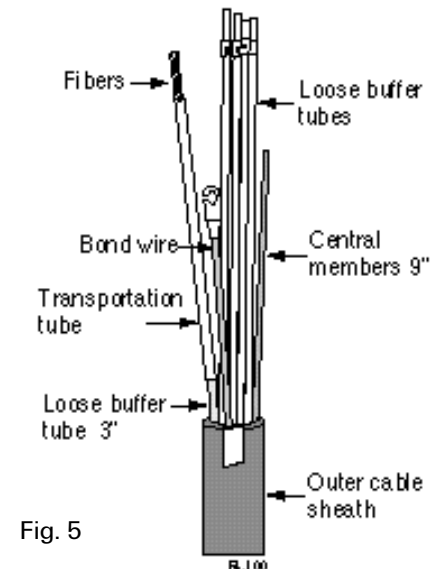
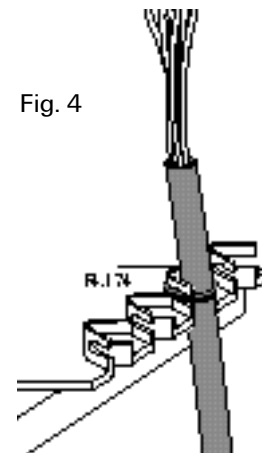
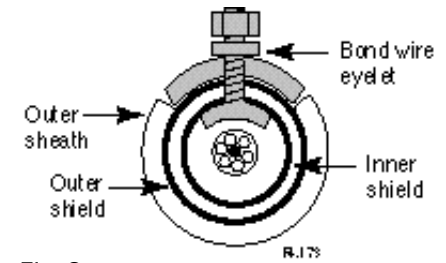
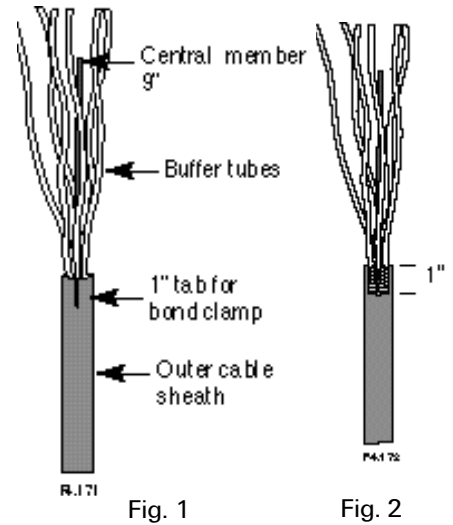

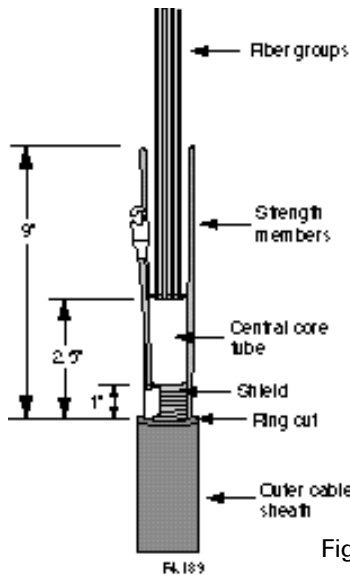

Fig. 6

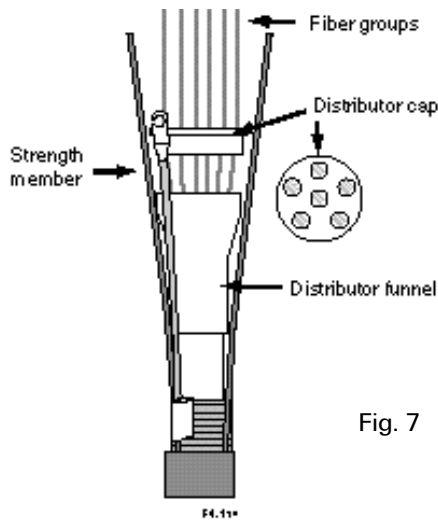

Fig. 7

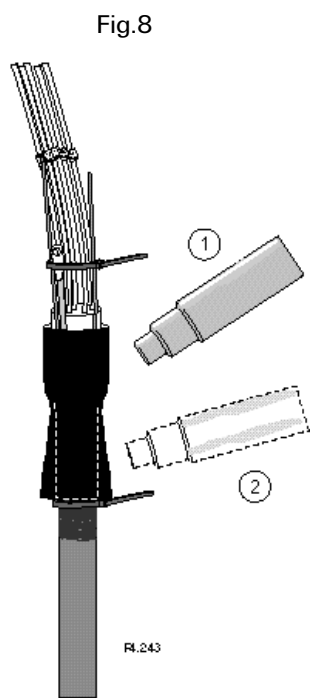

Fig.8



Fig. 9

7.2 Loose Buffer Tube Cable - Midspan Opening Preparation

Important: A FOSC ACC B Closure Basket - LBT is required for storing the uncut loose buffer tubes in the B2 and B4 closures..

1. Clean the cable and remove 90" of cable sheath (and shield, if present).
2. Prepare both sides of the midspan opening as described in Section 7.1, but do not remove buffer tubes from fibers that will be looped, uncut through the closure. Refer to the instructions included with the required FOSC ACC B Closure basket LBT kit for buffer tube storage procedures.

7.3 Central Core Tube Stranded Fiber Cable End Preparation (for installation in the oval port)

1. Clean the cable and remove 48" of the outer cable sheath.
2. If dual strength members (e.g., LXE) or multiple metallic strength members (eg., crossply) are present: expose each strength member and cut it off 9" from the ring cut. (Figure 6)
3. If multiple non-metallic strength members (eg., EST) are present: cut them off at the ring cut.
4. If metal shield is present: Remove all but 1" of the metal shield. (Figure 6) Pry open a 1" tab in the exposed metal shield where the shield overlaps. Crimp the bond clamp onto the edge of the shield.
5. Attach the cable to the FOSC closure work stand with a tie wrap. (See Figure 4)
6. Cut the central core tube 2-1/2" from the ring cut (1-1/2" beyond the metal shield if present) and remove the excess tube. (Fig. 6)
7. Separate the fiber groups and clean the exposed components with a clean cloth and company-approved cleaning solution.
8. Slide the small end of the distributor funnel over the fiber groups, and slide it down over the central core tube.
9. Place one fiber group in each hole of the distributor cap. (Fig. 7)
10. Carefully slide the distributor cap down until it seats in the funnel.
11. Place the fibers from each distributor cap hole into a transportation tube, and slide the tube down into the hole. Place an identification marker on each transportation tube. On feeder tubes (in cable) place the markers 6" above the ring cut. On distribution tubes (out cable) place the markers 9" above the ring cut.
12. Place a tie-wrap 1" below the ring cut. Slide the 4"-long black heat-shrinkable tube over the cable components and allow it to rest on the tie wrap. The top of the tube should be roughly 1/2" below the top of the funnel.
13. Place a tie wrap around the transportation tubes to hold them in place.
14. With the CV1981 on setting 6, begin shrinking the tube around the top of the funnel. After recovering 1" of tube on funnel, pause for 15 seconds to allow the adhesive to set on the funnel. Complete shrinking the tube. (Fig. 9)
15. After the tube has cooled, remove the tie wraps.

7.4 Central Core Tube Ribbon Fiber Cable End Preparation (for installation in the oval port)

Important: A metal slack basket (FOSC ACC B Basket-Ribbon) and ribbon-sized transportation tubing (FOSC ACC TTube Ribn) are required.

1. Perform Steps 1-5 in Section 7.3
2. Carefully cut the central core tube 12" from the sheath ring cut as in Figure 10.
3. Separate the fiber groups or ribbons and clean the exposed components with a clean cloth and company-approved cleaning solution. If ribbon cable is used, stack the ribbons in the order in which they appear in the central core tube. Temporarily wrap a piece of vinyl tape around the ribbons about 1" from the tube to help keep the ribbons stacked.

Note: If the ribbons are not stacked properly, or if they are twisted, light signals may be attenuated.

7.5 Central Core Tube Cable - Standard Fiber and Ribbon Midspan Opening (for Installation in the Oval Port)

Important: If using ribbon cable, a metal basket (FOSC ACC B Basket Ribbon) and ribbon-sized transportation tubing (FOSC ACC TTube Ribn) are required. If using stranded fiber, expressed fibers are stored on the bottom splice tray or in a metal basket (FOSC ACC B Basket CCT).

1. Clean the cable and make two ring cuts 90" apart, centering the point at which the cable will be spliced. Remove the outer cable sheath between the ring cuts.
2. Prepare both sides of the midspan opening as described in Section 7.3.

7.6 Loose Buffer Tube Ribbon Cable Ends

Important: A metal slack basket (FOSC ACC B Basket-Ribbon) and ribbon-sized transportation tubing (FOSC ACC TTube Ribn) are required.

This section pertains to loose buffer tube cable that contains ribbons inside the individual loose buffer tubes. To prepare the cable, follow the instructions in Section 7.1 of this practice, but leave 12" of each loose buffer tube intact beyond the sheath ring cut. Do not install transportation tubes on the loose buffer tube ends.

7.7 Loose Buffer Tube Ribbon Cable Mid-Span Openings

Important: A metal slack basket (FOSC ACC B Basket-Ribbon) and ribbon-sized transportation tubing (FOSC ACC TTube Ribn) are required.

This section pertains to loose buffer tube cable that contains ribbons inside the individual loose buffer tubes. A mid-span opening of loose buffer tube ribbon cable can only be installed in the oval port. To prepare the cable, open 96" of cable, exposing the loose buffer tubes. Prepare as in Section 7.1, removing all but 12" of each buffer tube. Do not cut ribbons or install transportation tubes.

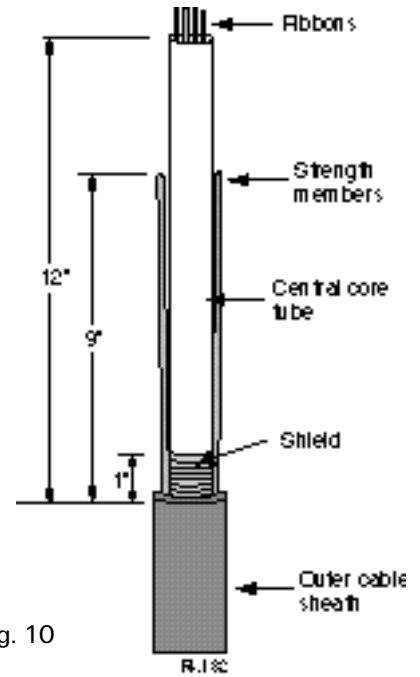
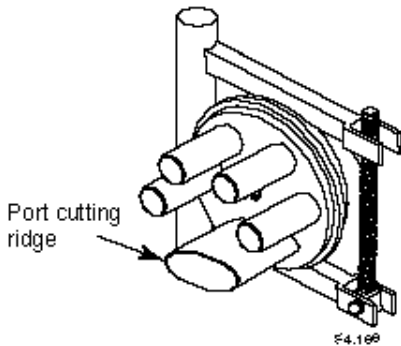
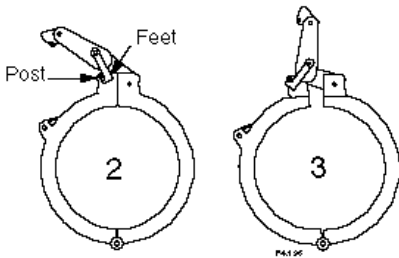
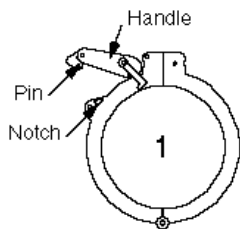
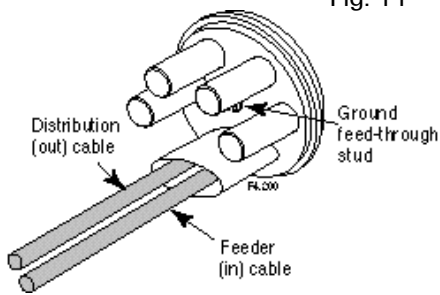

Fig. 10

Fig. 11



Splice Closure Installation Instructions

As indicated in Figure 11, the "right" side of the base is the feeder (or in cable) side of a B closure, and the "left" side is the distribution (or out cable) side.

8. Remove Dome/Base Seal

1. Push the handle to the side to release the pin from the notch, then lift the handle. See Figure 12, Step 1.
2. Hook the "feet" of the handle behind the two posts and pry open one half of the clamp. See Figure 12, Steps 2 and 3.
3. Move the handle out of the way and gently tap the other half of the clamp to release it from the dome.
4. Support the dome before removing the clamp. Remove dome and o-ring. Hang o-ring on top of dome.
5. Protect dome from dirt during installation. **DO NOT SIT ON DOME!**
6. Attach the B base to the FOSC closure work stand. (Figure 13)

9. Install Cables

1. Select the appropriate port to open on the B base. These instructions assume that the oval port is selected.

Note: An oval port seal is included with most B closure kits. If you intend to open a round port, you will need one FOSC ACC Cable Seal 1XX kit to seal each opened round port. (See Section 12)

2. Cut the end off the selected port at the ridge with a hacksaw. (Figure 13)

Important: Slide tubular cable port seal over cables before installing cables in the port!!! The arrow on the seal should point at the base. (If you forget this step, you may need to order a wraparound oval port sleeve.)

3. Insert the cables through the port. For cables installed in the oval port, place the distribution cable on the left, and the feeder cable on the right. (See Figure 11) Align each cable so that the sealed end of the cable block (if present) is flush with the inside edge of the opened port. If no cable block is used, align inside edge of port with the end of the vinyl tape wrap (loose buffer tube cable) or the distribution funnel cap (central core tube cable). For cables installed in the oval port, place the distribution (out) cable on the left, and the feeder (in) cable on the right (Fig. 11).

9.1 Bond and Ground Metal Components

Insert the "hooked" bond wire eyelet between the bolt head and square washer opposite the port being used. Do not tighten the bolt until strength members are placed under the washer.

B closures support two methods of external grounding:

- Grounding using the FOSC ACC fiber ext grd kit closure (common or isolated grounding)
- Grounding using ground feed-through studs (one stud available in B4, two in B2) (See Figure 11)

Note: All steel strength members are bonded in common when captured under a square washer.

9.2 Attach Central Members

To attach central members from the cables to the metal tray bracket, follow these steps:

1. Align the central member with the square washer with which it will be attached to the base. Trim the central member 1/4" beyond the edge of the square washer.
2. Loosen the square washer and place the central member(s) underneath it. Tighten the square washer to secure the central members against the base. (Figure 14)
3. It may be necessary with large central members to place a piece of the member under each side of the washer to keep the washer level.

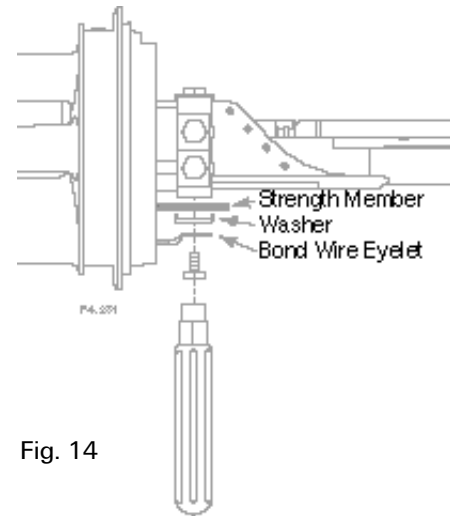

Fig. 14

9.3 Seal Cables in Oval Port

To seal cables in the oval port, follow these steps:

1. Clean the port and 8" of the cable sheath beyond the port edge with the supplied cleaning tissue.
2. Abrade the port and 8" of cable with the supplied abrasive strip, and remove any abraded material from the port and sheath with a clean, dry cloth.
3. Slide the tubular cable port seal up around the port and cable. Be sure that the inside edge of the tube butts against the B base. Squeeze the tube down onto the base and place a white pencil mark on the cable just beyond the end of the tube.
4. Slide the tube back off the port.
5. Wrap one lap of aluminum tape around each cable. The edge of the tape closest to the closure should be 1/2" inside the white mark on the cable as shown in Figure 15.
6. Re-install the heat-shrinkable tube, being sure that the edge of the tube butts against the B base.
7. Install the branch-off clip as shown. The clip's base must not touch the tube. (Figure 16)
8. Tie the cables together with a tie wrap 1" beyond the end of the tube.
9. Using a CV1981 hot-air gun on setting 10, begin shrinking the tube at the end closest to the base of the closure. Direct the air around the tube until the green paint turns black.
10. Continue heating the remainder of the tube as evenly as possible until it has completely conformed to the cable(s). (Figure 17)
11. The seal is completely installed when:
 - Melted adhesive appears at the cable end of the tube around the branch-off clip, and
 - All green thermochromic paint on the tube has turned black.

Fig. 15

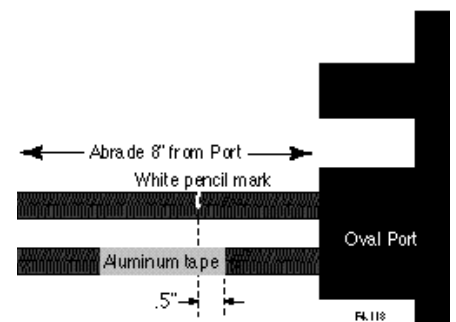

Fig. 16

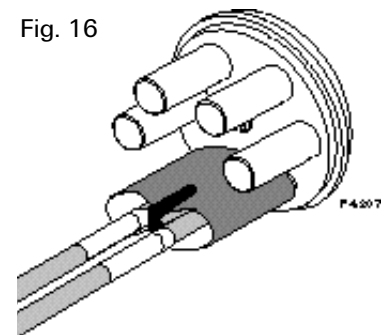
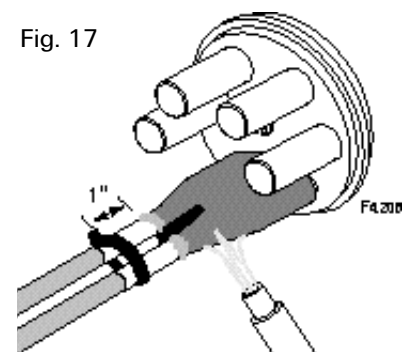

Fig. 17



Note: Do not overheat the tube or the closure base.

Fig. 18

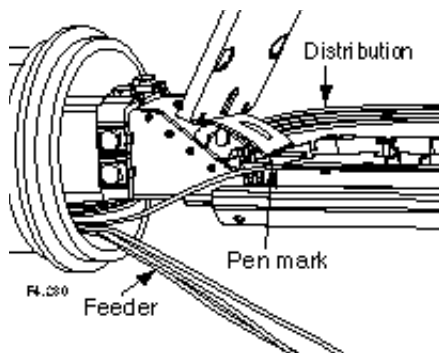

Fig. 19

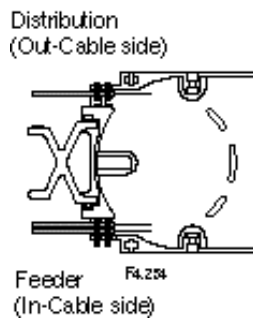
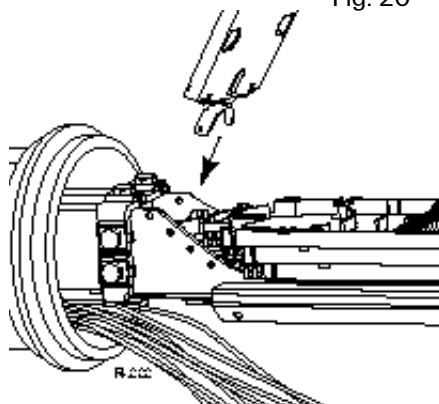

Fig. 20



10. Fiber Organizing and Splicing

10.1 Loose Buffer Tube Cable and Central Core Tube Cable - Stranded Fiber with Funnel

Note: For mid-span openings, stranded fibers are stored in a FOSC ACC B Basket-CCT. Loose buffer tubes are stored in a FOSC ACC B Basket-LBT.

1. If multiple trays are present, fill the bottom tray first. Use the supplied tray support wedge to hold it out of the way.
2. Remove the tray cover and route the "feeder" (in) and "distribution" (out) tubes to the appropriate sides of the tray.
3. Place a pen mark on each tube 1/4" beyond the tie-down slots. Use a buffer tube cutter to cut each tube at the mark, and remove the excess tube from each fiber group. (Figure 18)
4. Secure the transportation tubes to the tray with two tie wraps as shown. (Figure 19)
5. Arrange the fiber around the tray for storage. Replace the tray cover.
6. Repeat Steps 1-5 for each tray until all fiber has been stored on a tray.

10.2 Central Core Tube Stranded Fiber Cable - Alternative Method

If funnels are not used, route both central core tubes directly onto either side of the bottom splice organizer tray (or into an optional metal basket, the FOSC ACC B basket CCT. Refer to instructions included with this kit for storage of fibers). Attach the core tubes to the tray with two tie wraps. The unspliced fibers are stored in the bottom tray. A maximum of 48 fibers can be stored on each tray. Remove the splice modules if necessary. Add intertray jumpers as described in Section 10.5 to route the fibers onto upper trays for splicing.

10.3 Central Core Tube and Loose Buffer Tube Cable - Ribbon Fiber

Route both central core tubes into an optional metal basket, the FOSC ACC B basket ribbon closure kit. Follow instructions included with this kit to route the ribbons onto upper trays for splicing.

10.4 Add/Remove Splice Trays

Additional splice trays are available in the FOSC ACC B tray closure kits. To add splice trays, align the tray pins with the holes in the base bracket. Squeeze the tray pins and slip the tray into the base bracket. (Figure 20)

To remove splice trays, reverse this procedure. (Use a screwdriver to pry the hinge away from the bracket if necessary.)

10.5 Add Intertray Jumpers

Fig. 21

If fiber placed on one tray is to be spliced with fiber from another tray or basket, you must use an intertray jumper to route the fiber to the desired tray. To create an intertray jumper, follow these steps:

1. Place appropriate intertray identification markers on a transportation tube. (Intertray ID markers are marked "1TO" through "4TO" and "1" through "4" to indicate which tray the jumper came from and which tray it is going to.)
2. Thread the desired fibers through the marked transportation tube (now called the intertray jumper).
3. Secure one end of the intertray jumper to the originating splice tray with two tie wraps. If you have to remove existing tie wraps, cut and replace them one at a time to avoid moving existing transportation tubes.
4. Guide the jumper underneath the tray mounting bracket to the appropriate destination tray and position it in the tray. (Figure 21)
5. With a pen, mark the jumper 1/4" beyond the tie wrap slot. Use the buffer tube cutter to cut the jumper at the mark, and secure the jumper to the splice tray with two tie wraps. The fibers may now be stored or spliced.

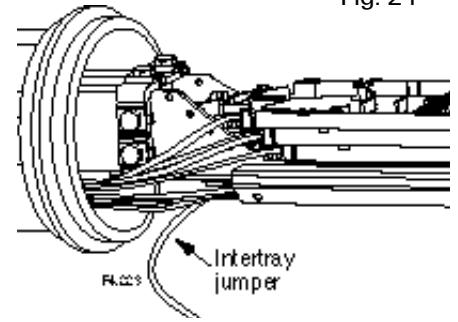

10.6 Splice Fibers and Store on Trays

Fiber splicing should be done in compliance with company-approved practices. This section outlines some basic splice organizing techniques to be followed in B closures:

1. Always begin splicing with the bottom tray. Lift the remaining trays and secure them with the tray support on the underside of the second tray.
2. Remove all stored, unspliced fibers from the tray and clean those that will be spliced. Refer to the splice manufacturer's instructions for directions on fiber splicing.

Note: Protect and strain-relieve fusion splices with fusion splice support sleeves or similar company-approved devices. It is not necessary to use silicone or similar compounds to secure the fibers in the splice holders.

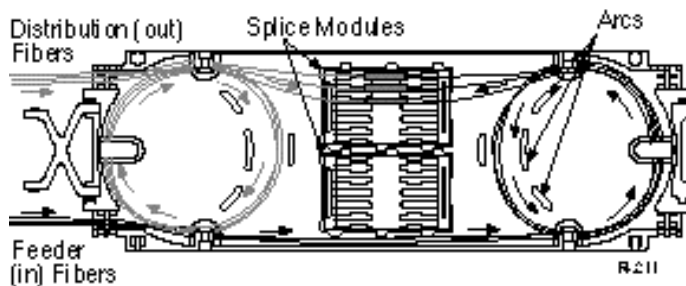

Fig. 22 Storing splices in "top" module

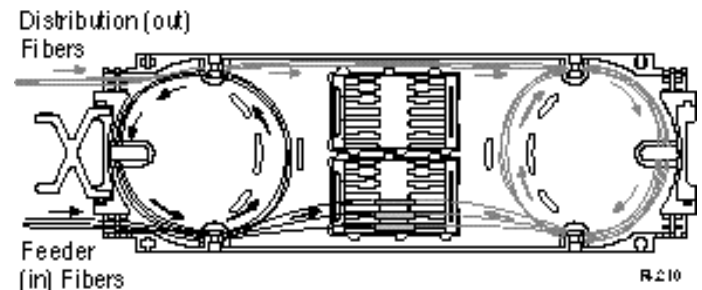

Fig. 23 Storing splices in "bottom" module

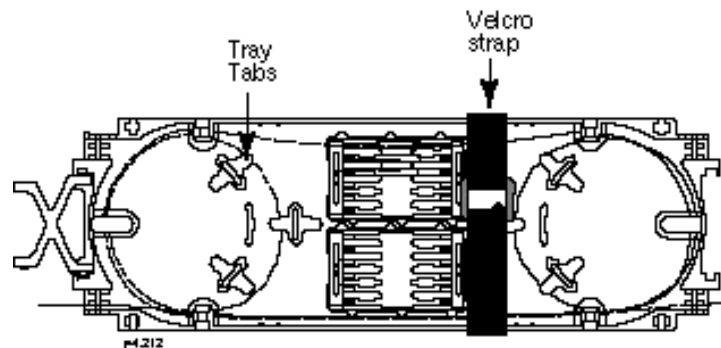
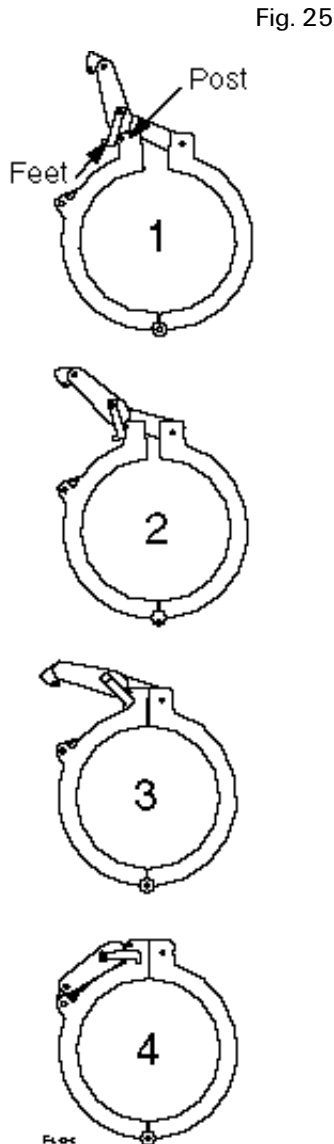

Fig. 24

3. Insert splices in the “top” and “bottom” splice modules and store slack fiber on the trays as shown in Figure 22 and 23. Install tray tabs if required (see Figure 24).
4. When all splices are completed and stored, replace the tray cover.
5. Secure all trays to the bottom tray bracket with Velcro strap as shown. (Figure 24)

11. Closing and Mounting Closure

11.1 Install Dome



1. If desiccant is to be used (optional - not supplied), install 75 grams of desiccant on top of the uppermost splice organizer tray. Secure it in place with the supplied velcro strap.
2. Clean the o-ring and the o-ring seating area with a clean, dry cloth. Use clean water or alcohol wipe if necessary. Sealing surfaces must be free of contaminants such as cable grease, cable threads, fibers, dirt, and dust. Inspect for damage. Re-install the o-ring.
3. Mount dome on base, aligning arrows on dome and base. Install clamp around the base/dome interface.
4. Position feet of handle in front of the two posts and push down on the handle to pull the two halves of the clamp together. See Figure 25, Steps 1-3.
5. Continue to push handle down until the small pin on the handle snaps into the triangular hole in the clamp. See Figure 25, Step 4.
6. A security lock or tie wrap can be inserted through the round holes in the handle and clamp to lock the closure.

11.2 Test Seals

Ensure that all heat-shrinkable parts are cool to the touch. Pressure-test the closure with no more than 5 psi. Thoroughly soap all seals and the valve to check for seal integrity.

Important: After flash testing, bleed all pressure from B closure through the valve.

11.3 Mount Closure

When the closure has successfully passed testing, it can be mounted for storage. For man-hole installations, strap the closure to a mounting rod or pipe (1-1/4" galvanized water pipe). The mounting rod is not supplied. For aerial applications, use the optional FOSC ACC univ aerial clamp kit. For wall or pole mounting, use the optional FOSC ACC A/B pole mount kit.

12. Adding Cables

Adding cables to a sealed B closure requires additional cable seal kits. Cable seal kits are available in several configurations, as described by the kit naming convention described below:

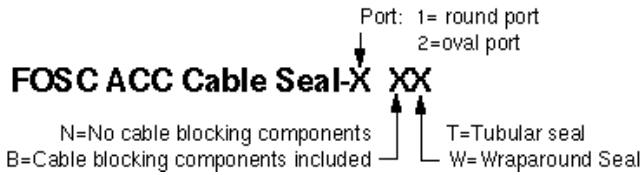

13. Removing Cable Seals

Important: When removing cable seals from a B closure, first remove the dome and make sure that the cable's strength members are securely attached to the closure's base.

1. Re-heat the seal with a hot-air gun.
2. Lightly score the seal with a knife until a split appears in the seal.
3. Apply heat to the split until it runs the length of the seal.
4. Pull the seal away from the cables and closure with a pair of pliers.
5. Any old adhesive remaining on the cables and closure can remain in place.
6. If necessary, cables can be replaced with half-inch plastic rods sold as FOSC ACC Port Rod 0.5 kits.

Tyco Electronics Corporation

8000 Purfoy Road
Fuquay-Varina, NC 27526-3000
Tel.: 919-557-8900
Fax: 919-557-8498
www.tycoelectronics.com

FOSC 400 is a trademark of Tyco Electronics Corporation

The information given herein, including drawings, illustrations and schematics which are intended for illustration purposes only, is believed to be reliable. However, Tyco Electronics makes no warranties as to its accuracy or completeness and disclaims any liability in connection with its use. Tyco Electronics' obligations shall only be as set forth in Tyco Electronics' Standard Terms and Conditions of Sale for this product and in no case will Tyco Electronics be liable for any incidental, indirect or consequential damages arising out of the sale, resale, use or misuse of the product. Users of Tyco Electronics products should make their own evaluation to determine the suitability of each such product for the specific application.